

DATA SHEET

74LVC2245A

Octal transceiver with direction pin,
30 Ω series termination resistors;
5 Volt tolerant input/output; 3-state

Product specification
Supersedes data of 1999 Jun 15

2002 Jun 10

Octal transceiver with direction pin, 30 Ω series termination resistors; 5 Volt tolerant input/output; 3-state **74LVC2245A**

FEATURES

- 5 V tolerant inputs/outputs for interfacing with 5 V logic
- Wide supply voltage range from 1.2 to 3.6 V
- CMOS low power consumption
- Direct interface with TTL levels
- Inputs accept voltages up to 5.5 V
- Complies with JEDEC standard no. 8-1A
- Integrated 30 Ω termination resistors
- Specified from -40 to $+85$ $^{\circ}\text{C}$ and -40 to $+125$ $^{\circ}\text{C}$.

DESCRIPTION

The 74LVC2245A is a high-performance, low-power, low-voltage, Si-gate CMOS device, superior to most advanced CMOS compatible TTL families.

Inputs can be driven from either 3.3 or 5 V devices. In 3-state operation, outputs can handle 5 V. These features allow the use of these devices as translators in a mixed 3.3 and 5 V environment.

The 74LVC2245A is an octal transceiver featuring non-inverting 3-state bus compatible outputs in both send and receive directions.

The 74LVC2245A features an output enable ($\overline{\text{OE}}$) input for easy cascading and a send/receive (DIR) input for direction control. $\overline{\text{OE}}$ controls the outputs so that the buses are effectively isolated.

The 74LVC2245A is designed with 30 Ω series termination resistors in both HIGH and LOW output stages to reduce line noise.

QUICK REFERENCE DATA

GND = 0 V; $T_{\text{amb}} = 25$ $^{\circ}\text{C}$; $t_r = t_f \leq 2.5$ ns.

SYMBOL	PARAMETER	CONDITIONS	TYPICAL	UNIT
$t_{\text{PHL}}/t_{\text{PLH}}$	propagation delay A_n to B_n , B_n to A_n	$C_L = 50$ pF; $V_{\text{CC}} = 3.3$ V	3.3	ns
C_I	input capacitance		4.0	pF
C_{PD}	power dissipation capacitance per buffer	$V_{\text{CC}} = 3.3$ V; notes 1 and 2	13	pF

Notes

1. C_{PD} is used to determine the dynamic power dissipation (P_D in μW).

$$P_D = C_{\text{PD}} \times V_{\text{CC}}^2 \times f_i + \Sigma(C_L \times V_{\text{CC}}^2 \times f_o) \text{ where:}$$

f_i = input frequency in MHz;

f_o = output frequency in MHz;

C_L = output load capacitance in pF;

V_{CC} = supply voltage in Volts;

$\Sigma(C_L \times V_{\text{CC}}^2 \times f_o)$ = sum of the outputs.

2. The condition is $V_I = \text{GND}$ to V_{CC} .

Octal transceiver with direction pin, 30 Ω series
termination resistors; 5 Volt tolerant input/output; 3-state

74LVC2245A

ORDERING INFORMATION

TYPE NUMBER	PACKAGE				
	TEMPERATURE RANGE	PINS	PACKAGE	MATERIAL	CODE
74LVC2245AD	-40 to +125 °C	20	SO	plastic	SOT163-1
74LVC2245ADB	-40 to +125 °C	20	SSOP	plastic	SOT339-1
74LVC2245APW	-40 to +125 °C	20	TSSOP	plastic	SOT360-1

FUNCTION TABLE

See note 1.

INPUTS		INPUTS/OUTPUTS	
$\overline{\text{OE}}$	DIR	A_n	B_n
L	L	A = B	inputs
L	H	inputs	B = A
H	X	Z	Z

Note

- H = HIGH voltage level;
L = LOW voltage level;
X = don't care;
Z = high-impedance OFF-state.

PINNING

PIN	SYMBOL	DESCRIPTION
1	DIR	direction control input
2, 3, 4, 5, 6, 7, 8, 9	A_0 to A_7	data inputs/outputs
10	GND	ground (0 V)
11, 12, 13, 14, 15, 16, 17, 18	B_7 to B_0	data inputs/outputs
19	$\overline{\text{OE}}$	output enable input (active LOW)
20	V_{CC}	supply voltage

Octal transceiver with direction pin, 30 Ω series termination resistors; 5 Volt tolerant input/output; 3-state

74LVC2245A

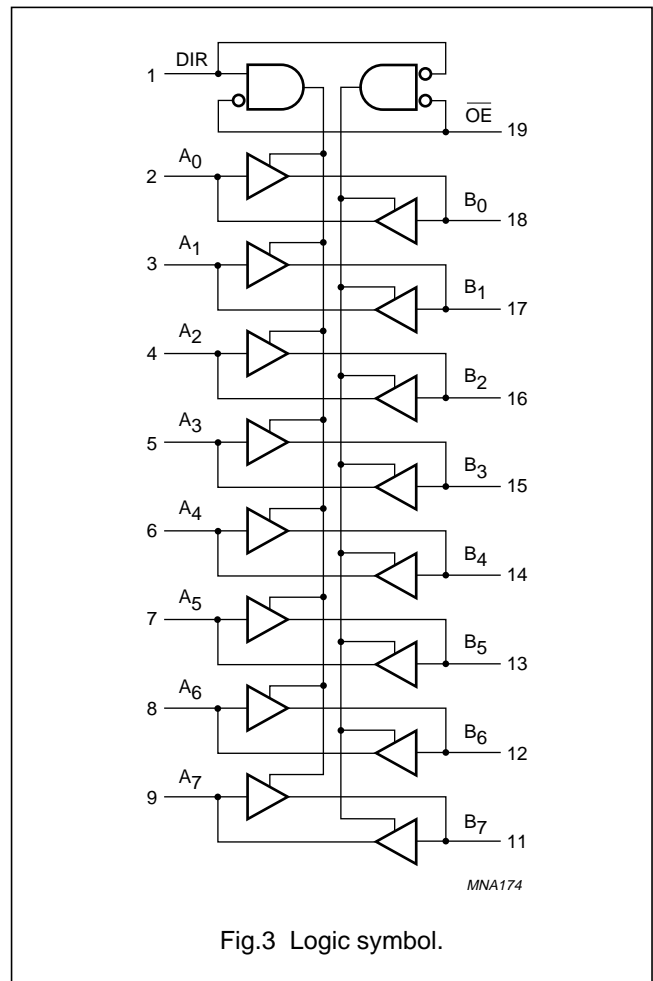
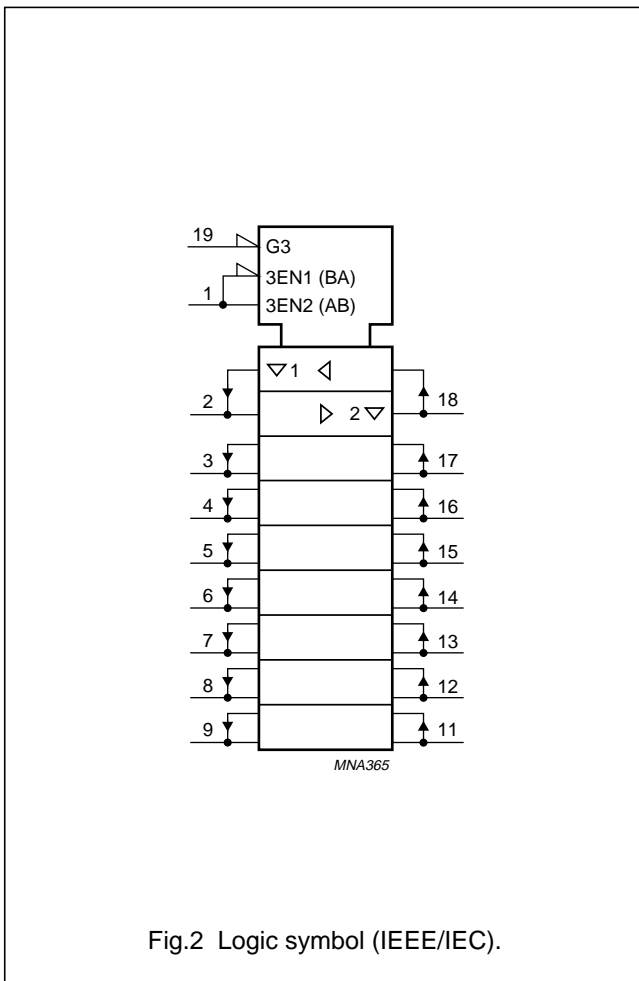
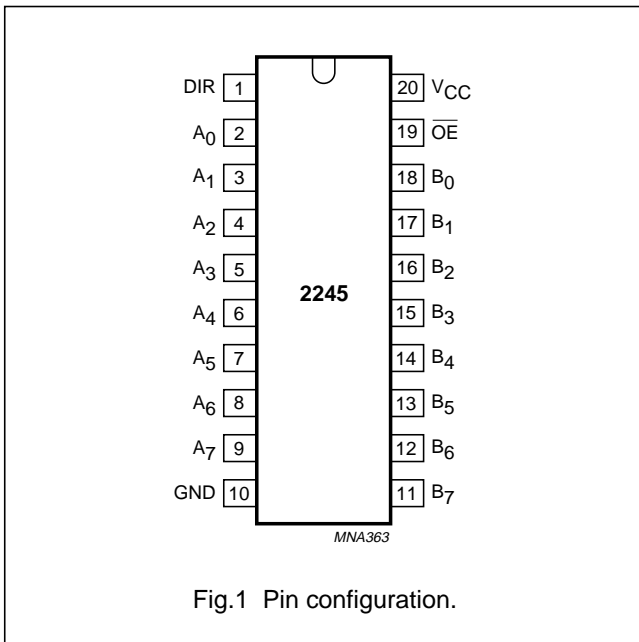

Octal transceiver with direction pin, 30 Ω series
termination resistors; 5 Volt tolerant input/output; 3-state

74LVC2245A

RECOMMENDED OPERATING CONDITIONS

SYMBOL	PARAMETER	CONDITIONS	MIN.	MAX.	UNIT
V _{CC}	supply voltage	for maximum speed performance	2.7	3.6	V
		for low-voltage applications	1.2	3.6	V
V _I	input voltage		0	5.5	V
V _O	output voltage	output HIGH or LOW state	0	V _{CC}	V
		output 3-state	0	5.5	V
T _{amb}	ambient temperature		-40	+125	°C
t _r , t _f	input rise and fall times	V _{CC} = 1.2 to 2.7 V	0	20	ns/V
		V _{CC} = 2.7 to 3.6 V	0	10	ns/V

LIMITING VALUES

In accordance with the Absolute Maximum Rating System (IEC 60134); voltages are referenced to GND (ground = 0 V).

SYMBOL	PARAMETER	CONDITIONS	MIN.	MAX.	UNIT
V _{CC}	supply voltage		-0.5	+6.5	V
I _{IK}	input diode current	V _I < 0	-	-50	mA
V _I	input voltage	note 1	-0.5	+6.5	V
I _{OK}	output diode current	V _O > V _{CC} or V _O < 0	-	±50	mA
V _O	output voltage	output HIGH or LOW state; note 1	-0.5	V _{CC} + 0.5	V
		output 3-state; note 1	-0.5	+6.5	V
I _O	output source or sink current	V _O = 0 to V _{CC}	-	±50	mA
I _{GND} , I _{CC}	V _{CC} or GND current		-	±100	mA
T _{stg}	storage temperature		-65	+150	°C
P _{tot}	power dissipation per package SO	above 70 °C derate linearly with 8 mW/K	-	500	mW
	SSOP and TSSOP	above 60 °C derate linearly with 5.5 mW/K	-	500	mW

Note

- The input and output voltage ratings may be exceeded if the input and output current ratings are observed.

Octal transceiver with direction pin, 30 Ω series
termination resistors; 5 Volt tolerant input/output; 3-state

74LVC2245A

DC CHARACTERISTICS

Over recommended operating conditions; voltages are referenced to GND (ground = 0 V).

SYMBOL	PARAMETER	TEST CONDITIONS		T_{amb} (°C)					UNIT
		OTHER	V_{CC} (V)	-40 to +85			-40 to +125		
				MIN.	TYP. ⁽¹⁾	MAX.	MIN.	MAX.	
V_{IH}	HIGH-level input voltage		1.2	V_{CC}	–	–	V_{CC}	–	V
			2.7 to 3.6	2.0	–	–	2.0	–	V
V_{IL}	LOW-level input voltage		1.2	–	–	0	–	0	V
			2.7 to 3.6	–	–	0.8	–	0.8	V
V_{OH}	HIGH-level output voltage	$V_I = V_{IH}$ or V_{IL} ; $I_O = -100 \mu A$	2.7 to 3.6	$V_{CC} - 0.2$	V_{CC}	–	$V_{CC} - 0.3$	–	V
		$V_I = V_{IH}$ or V_{IL} ; $I_O = -6 mA$	2.7	$V_{CC} - 0.5$	–	–	$V_{CC} - 0.65$	–	V
		$V_I = V_{IH}$ or V_{IL} ; $I_O = -12 mA$	3.0	$V_{CC} - 0.8$	–	–	$V_{CC} - 1$	–	V
V_{OL}	LOW-level output voltage	$V_I = V_{IH}$ or V_{IL} ; $I_O = 100 \mu A$	2.7 to 3.6	–	0	0.2	–	0.3	V
		$V_I = V_{IH}$ or V_{IL} ; $I_O = 6 mA$	2.7	–	–	0.4	–	0.6	V
		$V_I = V_{IH}$ or V_{IL} ; $I_O = 12 mA$	3.0	–	–	0.55	–	0.8	V
I_{LI}	input leakage current	$V_I = 5.5 V$ or GND	3.6	–	± 0.1	± 5	–	± 20	μA
I_{OZ}	3-state output OFF-state current	$V_I = V_{IH}$ or V_{IL} ; $V_O = 5.5 V$ or GND	3.6	–	± 0.1	± 5	–	± 20	μA
I_{off}	power off leakage supply	V_I or $V_O = 5.5 V$	0.0	–	± 0.1	± 10	–	± 20	μA
I_{CC}	quiescent supply current	$V_I = V_{CC}$ or GND; $I_O = 0$	3.6	–	0.1	10	–	40	μA
ΔI_{CC}	additional quiescent supply current per in. pin	$V_I = V_{CC} - 0.6 V$; $I_O = 0$	2.7 to 3.6	–	5	500	–	5000	μA

Note

1. All typical values are measured at $V_{CC} = 3.3 V$ and $T_{amb} = 25 ^\circ C$.

Octal transceiver with direction pin, 30 Ω series
termination resistors; 5 Volt tolerant input/output; 3-state

74LVC2245A

AC CHARACTERISTICSGND = 0 V; $t_r = t_f \leq 2.5$ ns.

SYMBOL	PARAMETER	WAVEFORMS	T_{amb} (°C)					UNIT
			-40 to +85			-40 to +125		
			MIN.	TYP.	MAX.	MIN.	MAX.	
V_{CC} = 1.2 V								
t_{PHL}/t_{PLH}	propagation delay A_n to B_n ; B_n to A_n	see Figs 4 and 6	–	26	–	–	–	ns
t_{PZH}/t_{PZL}	3-state output enable time \overline{OE} to A_n ; \overline{OE} to B_n	see Figs 5 and 6	–	28	–	–	–	ns
t_{PHZ}/t_{PLZ}	3-state output disable time \overline{OE} to A_n ; \overline{OE} to B_n	see Figs 5 and 6	–	12	–	–	–	ns
V_{CC} = 2.7 V								
t_{PHL}/t_{PLH}	propagation delay A_n to B_n ; B_n to A_n	see Figs 4 and 6	1.5	4.0	7.3	1.5	9.5	ns
t_{PZH}/t_{PZL}	3-state output enable time \overline{OE} to A_n ; \overline{OE} to B_n	see Figs 5 and 6	1.5	5.9	9.5	1.5	12.0	ns
t_{PHZ}/t_{PLZ}	3-state output disable time \overline{OE} to A_n ; \overline{OE} to B_n	see Figs 5 and 6	1.5	3.8	6.9	1.5	9.0	ns
V_{CC} = 3.0 to 3.6 V; note 1								
t_{PHL}/t_{PLH}	propagation delay A_n to B_n ; B_n to A_n	see Figs 4 and 6	1.5	3.3	6.3	1.5	8.0	ns
t_{PZH}/t_{PZL}	3-state output enable time \overline{OE} to A_n ; \overline{OE} to B_n	see Figs 5 and 6	1.5	4.7	8.2	1.5	10.5	ns
t_{PHZ}/t_{PLZ}	3-state output disable time \overline{OE} to A_n ; \overline{OE} to B_n	see Figs 5 and 6	1.7	3.4	5.9	1.7	7.5	ns
$t_{sk(0)}$	skew	note 2			1.0		1.5	ns

Notes

1. Typical values are measured at $V_{CC} = 3.3$ V.
2. Skew between any two outputs of the same package switching in the same direction. This parameter is guaranteed by design.

Octal transceiver with direction pin, 30 Ω series termination resistors; 5 Volt tolerant input/output; 3-state

74LVC2245A

AC WAVEFORMS

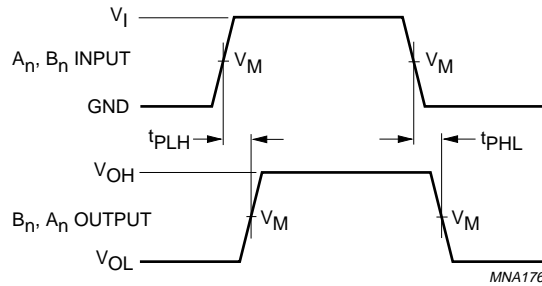

$V_M = 1.5\text{ V}$ at $V_{CC} \geq 2.7\text{ V}$;
 $V_M = 0.5V_{CC}$ at $V_{CC} < 2.7\text{ V}$;
 V_{OL} and V_{OH} are typical output voltage drop that occur with the output load.

Fig.4 The inputs A_n, B_n to outputs B_n, A_n propagation delays.

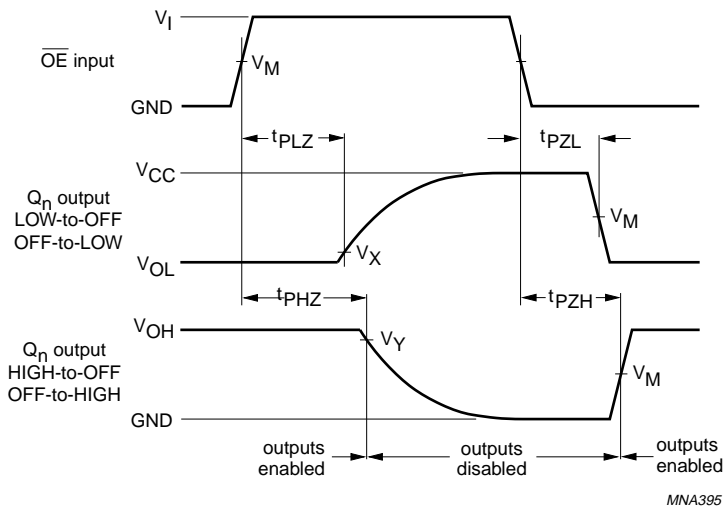

$V_M = 1.5\text{ V}$ at $V_{CC} \geq 2.7\text{ V}$;
 $V_M = 0.5V_{CC}$ at $V_{CC} < 2.7\text{ V}$;
 $V_X = V_{OL} + 0.3\text{ V}$ at $V_{CC} \geq 2.7\text{ V}$;
 $V_X = V_{OL} + 0.1\text{ V}$ at $V_{CC} < 2.7\text{ V}$;
 $V_Y = V_{OH} - 0.3\text{ V}$ at $V_{CC} \geq 2.7\text{ V}$;
 $V_Y = V_{OH} - 0.1\text{ V}$ at $V_{CC} < 2.7\text{ V}$.

V_{OL} and V_{OH} are typical output voltage drop that occur with the output load.

Fig.5 3-state enable and disable times.

Octal transceiver with direction pin, 30 Ω series termination resistors; 5 Volt tolerant input/output; 3-state

74LVC2245A

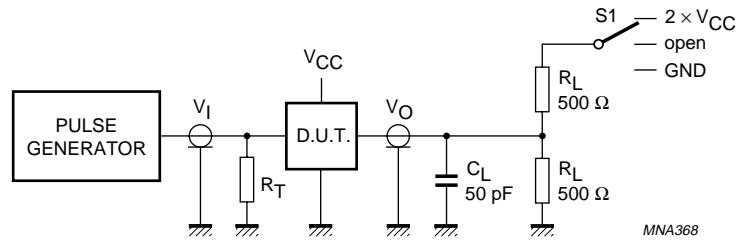

MNA368

SWITCH POSITION	
TEST	SWITCH
t_{PLH}/t_{PHL}	open
t_{PLZ}/t_{PZL}	$2 \times V_{CC}$
t_{PHZ}/t_{PZH}	GND

V_{CC}	V_I
$< 2.7 \text{ V}$	V_{CC}
$2.7 \text{ to } 3.6 \text{ V}$	2.7 V

Definitions for test circuits:

R_L = Load resistor.

C_L = Load capacitance including jig and probe capacitance.

R_T = Termination resistance should be equal to the output impedance Z_o of the pulse generator.

Fig.6 Load circuitry for switching times.

Octal transceiver with direction pin, 30 Ω series termination resistors; 5 Volt tolerant input/output; 3-state

74LVC2245A

PACKAGE OUTLINES

TSSOP20: plastic thin shrink small outline package; 20 leads; body width 4.4 mm

SOT360-1

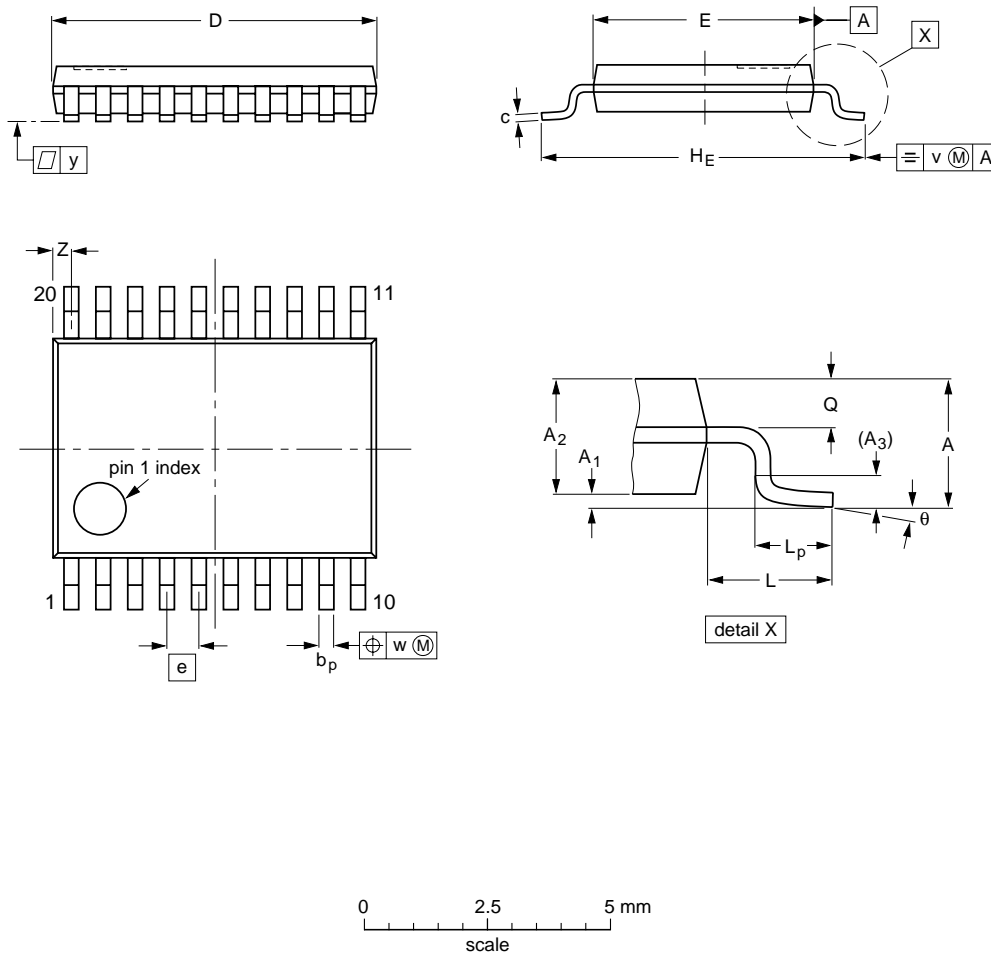

DIMENSIONS (mm are the original dimensions)

UNIT	A max.	A ₁	A ₂	A ₃	b _p	c	D ⁽¹⁾	E ⁽²⁾	e	H _E	L	L _p	Q	v	w	y	z ⁽¹⁾	θ
mm	1.10	0.15 0.05	0.95 0.80	0.25	0.30 0.19	0.2 0.1	6.6 6.4	4.5 4.3	0.65	6.6 6.2	1.0	0.75 0.50	0.4 0.3	0.2	0.13	0.1	0.5 0.2	8° 0°

Notes

1. Plastic or metal protrusions of 0.15 mm maximum per side are not included.
2. Plastic interlead protrusions of 0.25 mm maximum per side are not included.

OUTLINE VERSION	REFERENCES				EUROPEAN PROJECTION	ISSUE DATE
	IEC	JEDEC	EIAJ			
SOT360-1		MO-153				95-02-04 99-12-27

Octal transceiver with direction pin, 30 Ω series termination resistors; 5 Volt tolerant input/output; 3-state

74LVC2245A

SO20: plastic small outline package; 20 leads; body width 7.5 mm

SOT163-1

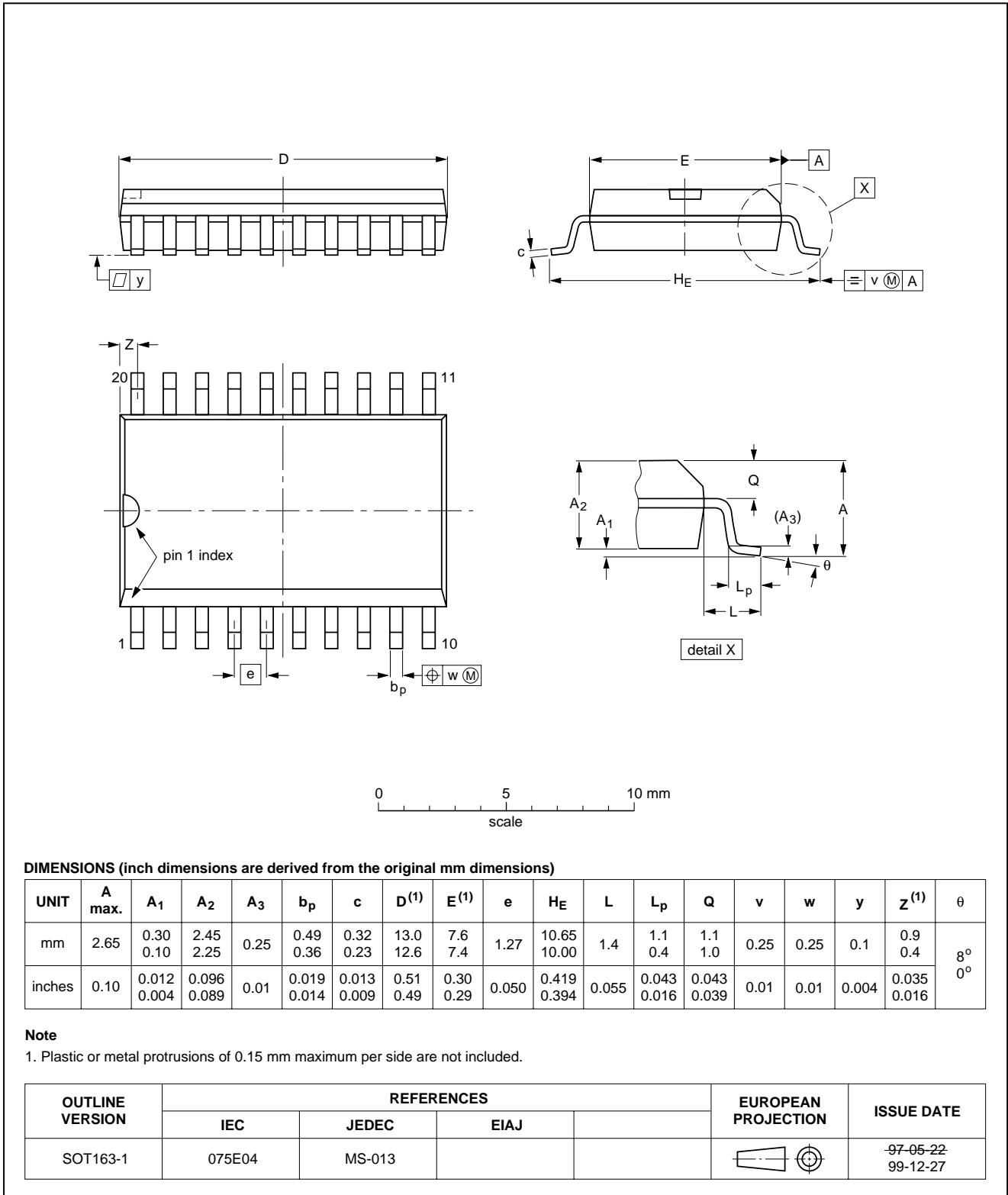

Octal transceiver with direction pin, 30 Ω series termination resistors; 5 Volt tolerant input/output; 3-state

74LVC2245A

SSOP20: plastic shrink small outline package; 20 leads; body width 5.3 mm

SOT339-1

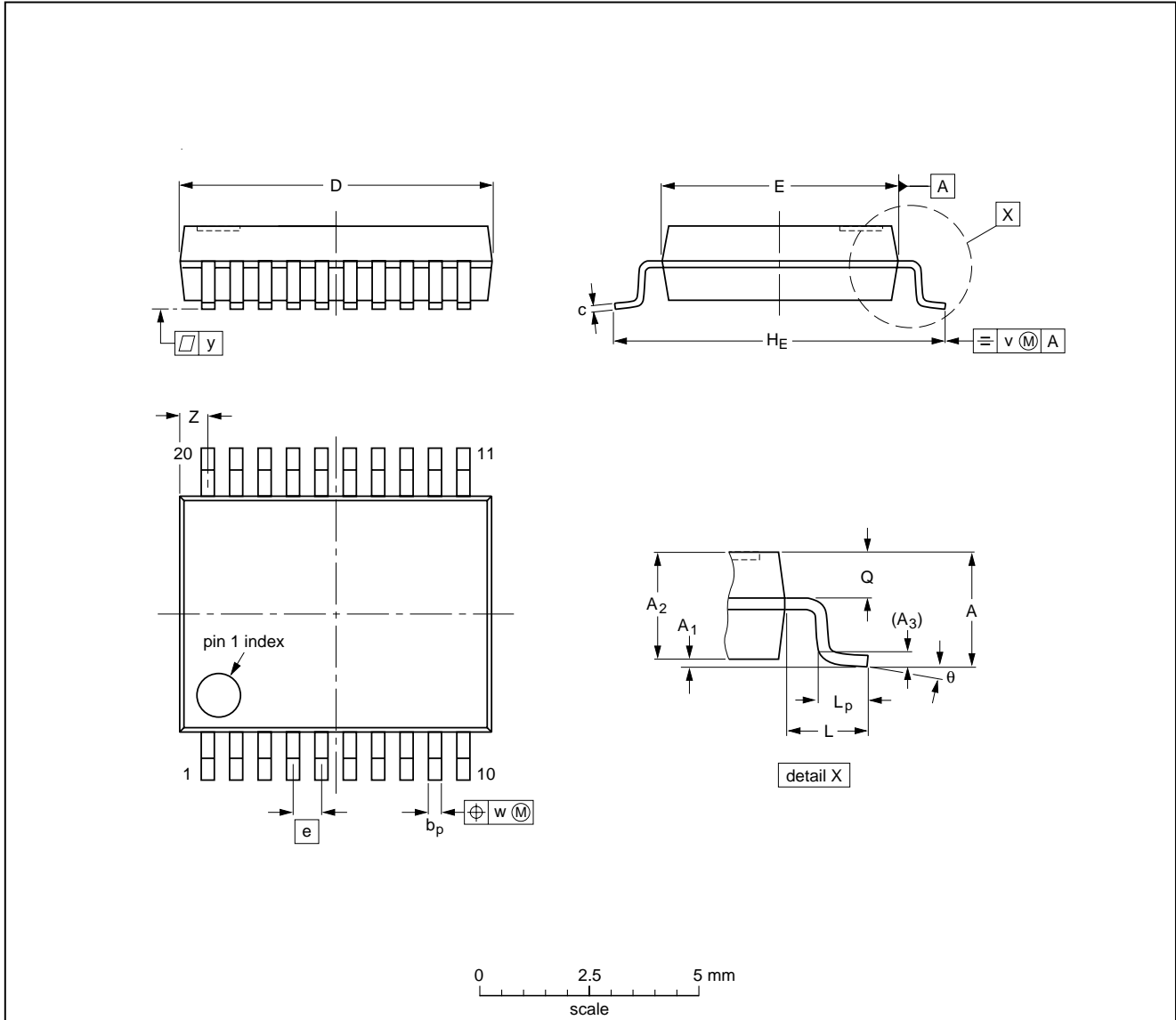

DIMENSIONS (mm are the original dimensions)

UNIT	A max.	A ₁	A ₂	A ₃	b _p	c	D ⁽¹⁾	E ⁽¹⁾	e	H _E	L	L _p	Q	v	w	y	z ⁽¹⁾	θ
mm	2.0	0.21 0.05	1.80 1.65	0.25	0.38 0.25	0.20 0.09	7.4 7.0	5.4 5.2	0.65	7.9 7.6	1.25	1.03 0.63	0.9 0.7	0.2	0.13	0.1	0.9 0.5	8° 0°

Note

1. Plastic or metal protrusions of 0.20 mm maximum per side are not included.

OUTLINE VERSION	REFERENCES				EUROPEAN PROJECTION	ISSUE DATE
	IEC	JEDEC	EIAJ			
SOT339-1		MO-150				95-02-04 99-12-27

Octal transceiver with direction pin, 30 Ω series termination resistors; 5 Volt tolerant input/output; 3-state

74LVC2245A

SOLDERING

Introduction to soldering surface mount packages

This text gives a very brief insight to a complex technology. A more in-depth account of soldering ICs can be found in our *"Data Handbook IC26; Integrated Circuit Packages"* (document order number 9398 652 90011).

There is no soldering method that is ideal for all surface mount IC packages. Wave soldering can still be used for certain surface mount ICs, but it is not suitable for fine pitch SMDs. In these situations reflow soldering is recommended.

Reflow soldering

Reflow soldering requires solder paste (a suspension of fine solder particles, flux and binding agent) to be applied to the printed-circuit board by screen printing, stencilling or pressure-syringe dispensing before package placement.

Several methods exist for reflowing; for example, convection or convection/infrared heating in a conveyor type oven. Throughput times (preheating, soldering and cooling) vary between 100 and 200 seconds depending on heating method.

Typical reflow peak temperatures range from 215 to 250 °C. The top-surface temperature of the packages should preferably be kept below 220 °C for thick/large packages, and below 235 °C for small/thin packages.

Wave soldering

Conventional single wave soldering is not recommended for surface mount devices (SMDs) or printed-circuit boards with a high component density, as solder bridging and non-wetting can present major problems.

To overcome these problems the double-wave soldering method was specifically developed.

If wave soldering is used the following conditions must be observed for optimal results:

- Use a double-wave soldering method comprising a turbulent wave with high upward pressure followed by a smooth laminar wave.
- For packages with leads on two sides and a pitch (e):
 - larger than or equal to 1.27 mm, the footprint longitudinal axis is **preferred** to be parallel to the transport direction of the printed-circuit board;
 - smaller than 1.27 mm, the footprint longitudinal axis **must** be parallel to the transport direction of the printed-circuit board.

The footprint must incorporate solder thieves at the downstream end.

- For packages with leads on four sides, the footprint must be placed at a 45° angle to the transport direction of the printed-circuit board. The footprint must incorporate solder thieves downstream and at the side corners.

During placement and before soldering, the package must be fixed with a droplet of adhesive. The adhesive can be applied by screen printing, pin transfer or syringe dispensing. The package can be soldered after the adhesive is cured.

Typical dwell time is 4 seconds at 250 °C.

A mildly-activated flux will eliminate the need for removal of corrosive residues in most applications.

Manual soldering

Fix the component by first soldering two diagonally-opposite end leads. Use a low voltage (24 V or less) soldering iron applied to the flat part of the lead. Contact time must be limited to 10 seconds at up to 300 °C.

When using a dedicated tool, all other leads can be soldered in one operation within 2 to 5 seconds between 270 and 320 °C.

Octal transceiver with direction pin, 30 Ω series
termination resistors; 5 Volt tolerant input/output; 3-state

74LVC2245A

Suitability of surface mount IC packages for wave and reflow soldering methods

PACKAGE ⁽¹⁾	SOLDERING METHOD	
	WAVE	REFLOW ⁽²⁾
BGA, LBGA, LFBGA, SQFP, TFBGA, VFBGA	not suitable	suitable
HBCC, HBGA, HLQFP, HSQFP, HSOP, HTQFP, HTSSOP, HVQFN, HVSON, SMS	not suitable ⁽³⁾	suitable
PLCC ⁽⁴⁾ , SO, SOJ	suitable	suitable
LQFP, QFP, TQFP	not recommended ⁽⁴⁾⁽⁵⁾	suitable
SSOP, TSSOP, VSO	not recommended ⁽⁶⁾	suitable

Notes

- For more detailed information on the BGA packages refer to the “(LF)BGA Application Note” (AN01026); order a copy from your Philips Semiconductors sales office.
- All surface mount (SMD) packages are moisture sensitive. Depending upon the moisture content, the maximum temperature (with respect to time) and body size of the package, there is a risk that internal or external package cracks may occur due to vaporization of the moisture in them (the so called popcorn effect). For details, refer to the Drypack information in the “Data Handbook IC26; Integrated Circuit Packages; Section: Packing Methods”.
- These packages are not suitable for wave soldering. On versions with the heatsink on the bottom side, the solder cannot penetrate between the printed-circuit board and the heatsink. On versions with the heatsink on the top side, the solder might be deposited on the heatsink surface.
- If wave soldering is considered, then the package must be placed at a 45° angle to the solder wave direction. The package footprint must incorporate solder thieves downstream and at the side corners.
- Wave soldering is suitable for LQFP, TQFP and QFP packages with a pitch (e) larger than 0.8 mm; it is definitely not suitable for packages with a pitch (e) equal to or smaller than 0.65 mm.
- Wave soldering is suitable for SSOP and TSSOP packages with a pitch (e) equal to or larger than 0.65 mm; it is definitely not suitable for packages with a pitch (e) equal to or smaller than 0.5 mm.

Octal transceiver with direction pin, 30 Ω series
termination resistors; 5 Volt tolerant input/output; 3-state

74LVC2245A

DATA SHEET STATUS

DATA SHEET STATUS ⁽¹⁾	PRODUCT STATUS ⁽²⁾	DEFINITIONS
Objective data	Development	This data sheet contains data from the objective specification for product development. Philips Semiconductors reserves the right to change the specification in any manner without notice.
Preliminary data	Qualification	This data sheet contains data from the preliminary specification. Supplementary data will be published at a later date. Philips Semiconductors reserves the right to change the specification without notice, in order to improve the design and supply the best possible product.
Product data	Production	This data sheet contains data from the product specification. Philips Semiconductors reserves the right to make changes at any time in order to improve the design, manufacturing and supply. Changes will be communicated according to the Customer Product/Process Change Notification (CPCN) procedure SNW-SQ-650A.

Notes

1. Please consult the most recently issued data sheet before initiating or completing a design.
2. The product status of the device(s) described in this data sheet may have changed since this data sheet was published. The latest information is available on the Internet at URL <http://www.semiconductors.philips.com>.

DEFINITIONS

Short-form specification — The data in a short-form specification is extracted from a full data sheet with the same type number and title. For detailed information see the relevant data sheet or data handbook.

Limiting values definition — Limiting values given are in accordance with the Absolute Maximum Rating System (IEC 60134). Stress above one or more of the limiting values may cause permanent damage to the device. These are stress ratings only and operation of the device at these or at any other conditions above those given in the Characteristics sections of the specification is not implied. Exposure to limiting values for extended periods may affect device reliability.

Application information — Applications that are described herein for any of these products are for illustrative purposes only. Philips Semiconductors make no representation or warranty that such applications will be suitable for the specified use without further testing or modification.

DISCLAIMERS

Life support applications — These products are not designed for use in life support appliances, devices, or systems where malfunction of these products can reasonably be expected to result in personal injury. Philips Semiconductors customers using or selling these products for use in such applications do so at their own risk and agree to fully indemnify Philips Semiconductors for any damages resulting from such application.

Right to make changes — Philips Semiconductors reserves the right to make changes, without notice, in the products, including circuits, standard cells, and/or software, described or contained herein in order to improve design and/or performance. Philips Semiconductors assumes no responsibility or liability for the use of any of these products, conveys no licence or title under any patent, copyright, or mask work right to these products, and makes no representations or warranties that these products are free from patent, copyright, or mask work right infringement, unless otherwise specified.

Philips Semiconductors – a worldwide company

Contact information

For additional information please visit <http://www.semiconductors.philips.com>. Fax: +31 40 27 24825

For sales offices addresses send e-mail to: sales.addresses@www.semiconductors.philips.com.

© Koninklijke Philips Electronics N.V. 2002

SCA74

All rights are reserved. Reproduction in whole or in part is prohibited without the prior written consent of the copyright owner.

The information presented in this document does not form part of any quotation or contract, is believed to be accurate and reliable and may be changed without notice. No liability will be accepted by the publisher for any consequence of its use. Publication thereof does not convey nor imply any license under patent- or other industrial or intellectual property rights.

Printed in The Netherlands

613508/03/pp16

Date of release: 2002 Jun 10

Document order number: 9397 750 09841

Let's make things better.

**Philips
Semiconductors**



PHILIPS